

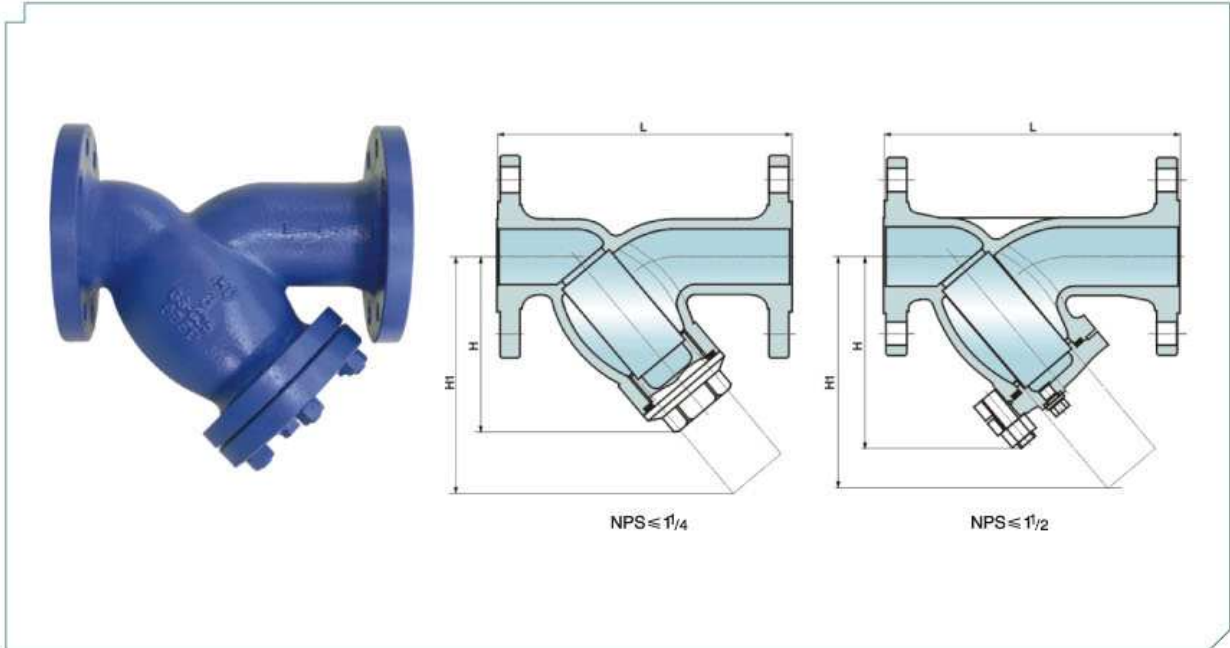

铸钢Y型过滤器  
CAST STEEL Y STRAINER

■ Class150 ~ Class300 & JIS 10K ~ JIS 20K 铸钢Y型过滤器 Cast Steel Y Strainer



■ 标准 Standards

法兰连接尺寸 End flange dimension: ASME B16.5 or JIS B 2238.

温压等级 Pressure-temperature ratings: ASME B16.34.

口径 Size		Class150 , JIS 10K				Class300 , JIS 20K			
		尺寸 Dimensions (mm)			重量 Weight(Kg)	尺寸 Dimensions (mm)			重量 Weight(Kg)
NPS	DN	L	H	H <sub>1</sub>		L	H	H <sub>1</sub>	
1/2	15	120	67	92	2	160	70	95	3
3/4	20	130	73	105	2	160	80	110	4
1	25	150	87	117	3	190	92	120	5
1 1/4	32	170	100	138	4	220	105	142	7
1 1/2	40	190	123	150	5	240	128	155	9
2	50	220	147	179	13	250	152	184	16
2 1/2	65	270	180	232	15	300	185	236	20
3	80	290	198	263	18	320	204	266	24
4	100	350	234	337	22	380	240	340	30
5	125	390	274	383	42	460	280	386	50
6	150	440	314	452	50	550	320	456	70
8	200	540	400	555	91	600	410	560	115
10	250	760	512	725	205	760	530	730	270
12	300	870	581	870	297	870	600	875	380
14	350	950	633	933	394	950	650	938	520